



Managing One and then Two Remote T90's Over a Secure Virtual Private Network

Barry Sharp, Bill Matson and Mark Lutz
The Boeing Company Shared Services Group

Barry.Sharp@boeing.com

Friday May 24, 2002 (Lord Mayor's Parlour at 8:30am)



Why...

- **Fast Track, High Visibility Project for New Airplane Product Development required upgrade to current Engineering HPC resource for Jan 1st 2002**
 - **Current T916 upgrade needed**
 - **If possible avoid re-learning for IT and Engineers**
 - **+ive...if known and familiar**
 - **+ive...operationally identical**
 - **+ive...binary compatibility**
 - **Keep risk low to improve chances for success**
 - **Get *job done* with minimum resource and cost**



Again, Why ? To design a Near Sonic Cruiser

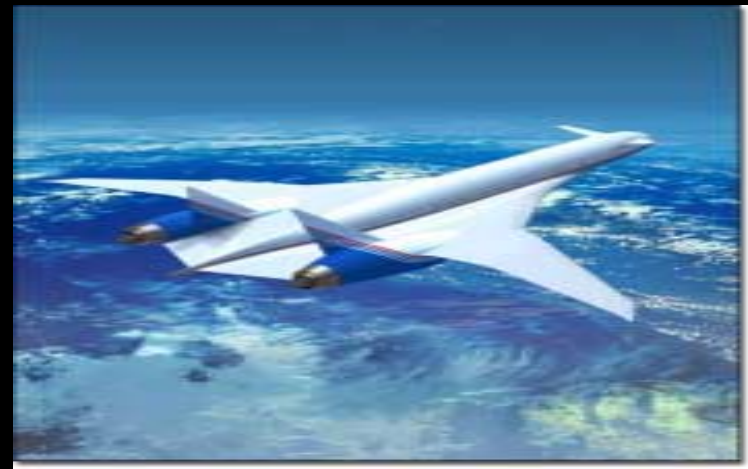



When did we do this ?

- **Oct 2001 through Apr 2002**
 - **Evaluated HPC vendors... settled on T932 or SX-6**
 - **Cray Inc. had a T932 and *maybe* an SX-6**
 - **T932 attractive but limited to max 4Gw SSD**
 - **SX-6 air cooled – easy installation**
 - **Insufficient SX-6 hands-on time available**
 - **SX-6 compiler problems seen but overcome**
 - **SX-6 price-performance was very attractive**
 - **SX-6 had just been released**



- **Selected T932 with 1024Mw and two 4Gw SSD boxes**
 - **T932 with 8Gw SSD met Boeing requirements**
 - **Cray's Professional Services proposed developing *unique* code to make two 4Gw SSD boxes appear as one 8Gw box - this was a break through for us**
 - **However there were some issues**
 - **T932 delivery proposed for March 1st 2002**
 - **T932 production not possible 'til April 1 2002**
 - **Data center required 3 months prep work for T932**
 - **Needed the T932 first week Jan 2002**

T932 8Gw SSD Configuration and Data Flow

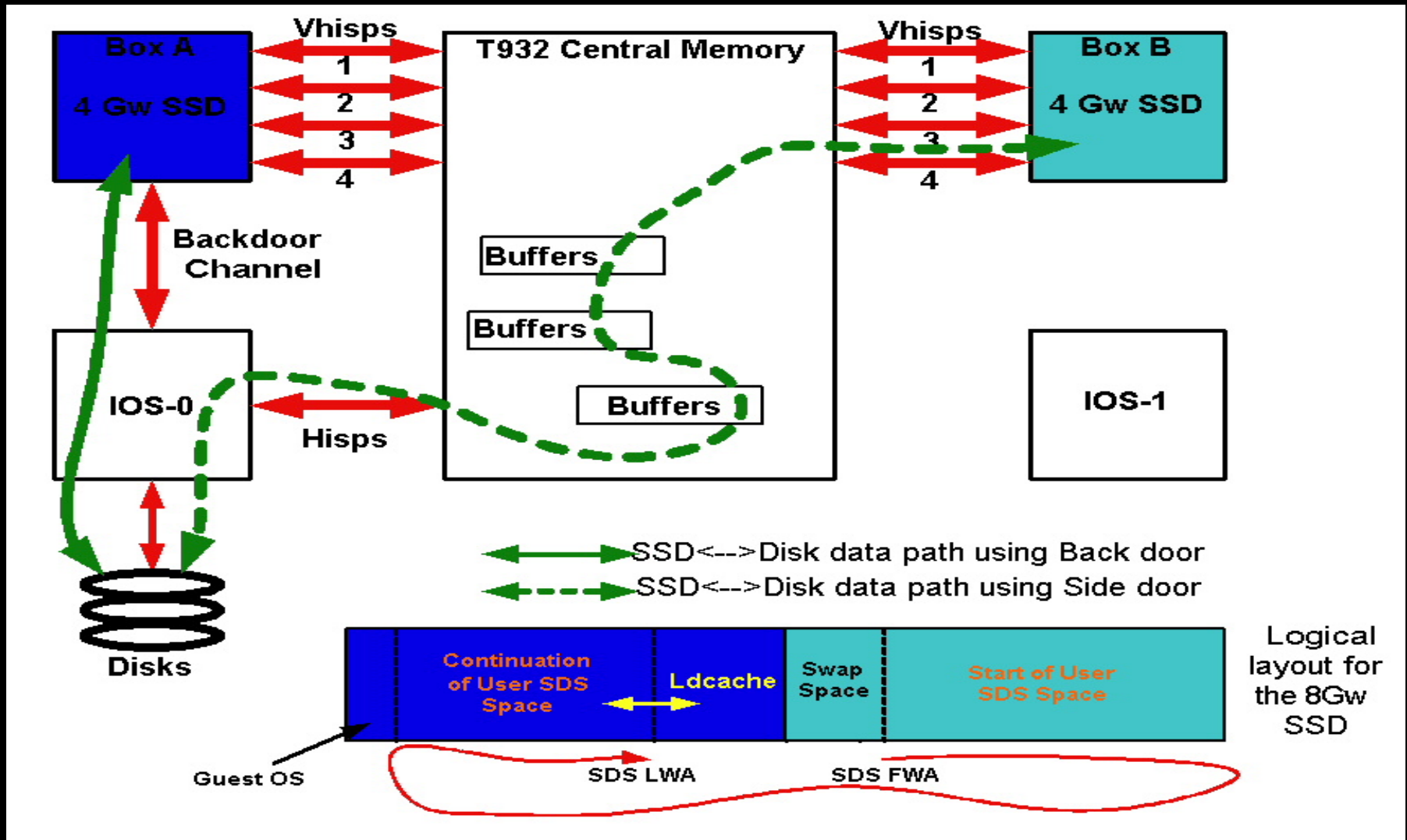



**It's now Dec ... big problem ... need T932 Jan 1st
Where was this all going to be done?**

- Cray Professional Services suggested we do it in Chippewa Falls**
 - Issues we faced**
 - Needed additional HPC computing NOW**
 - T932 w/8Gw SSD wasn't available**
 - Possible data center prep work delays**
 - Christmas holidays were looming**
 - Who wanted to spend Christmas in C.F.**
 - Could we operate T90s remotely ?**



How could we do this ?

- ...as we needed IMMEDIATE relief
 - A T916 was available in Chippewa Falls
 - Cray & Boeing prepared to work Christmas
 - Needed to install Boeing's own UNICOS 10
 - Needed a secure Network to C.F.
 - Needed to protect Boeing data in C.F.
 - Needed DMF, Tapes & Silo in C.F.
 - We really needed HELP from Cray



How to use, operate and manage a remote T916

- **Setting up the Virtual Private Network**
 - **VPN routers with hardware encryption**
 - **Boeing Security said OK... but ALL need classes**
 - **C.F. provided T1 line and a secure bay**
 - **Cray Network people said – “yes can do”**
 - **Operating the Boeing modified UNICOS 10 on a remote T916 was considered possible by IT**
 - **Shipped VPN routers, Tapes/Drives, Silo (9710)**

Virtual Private Network

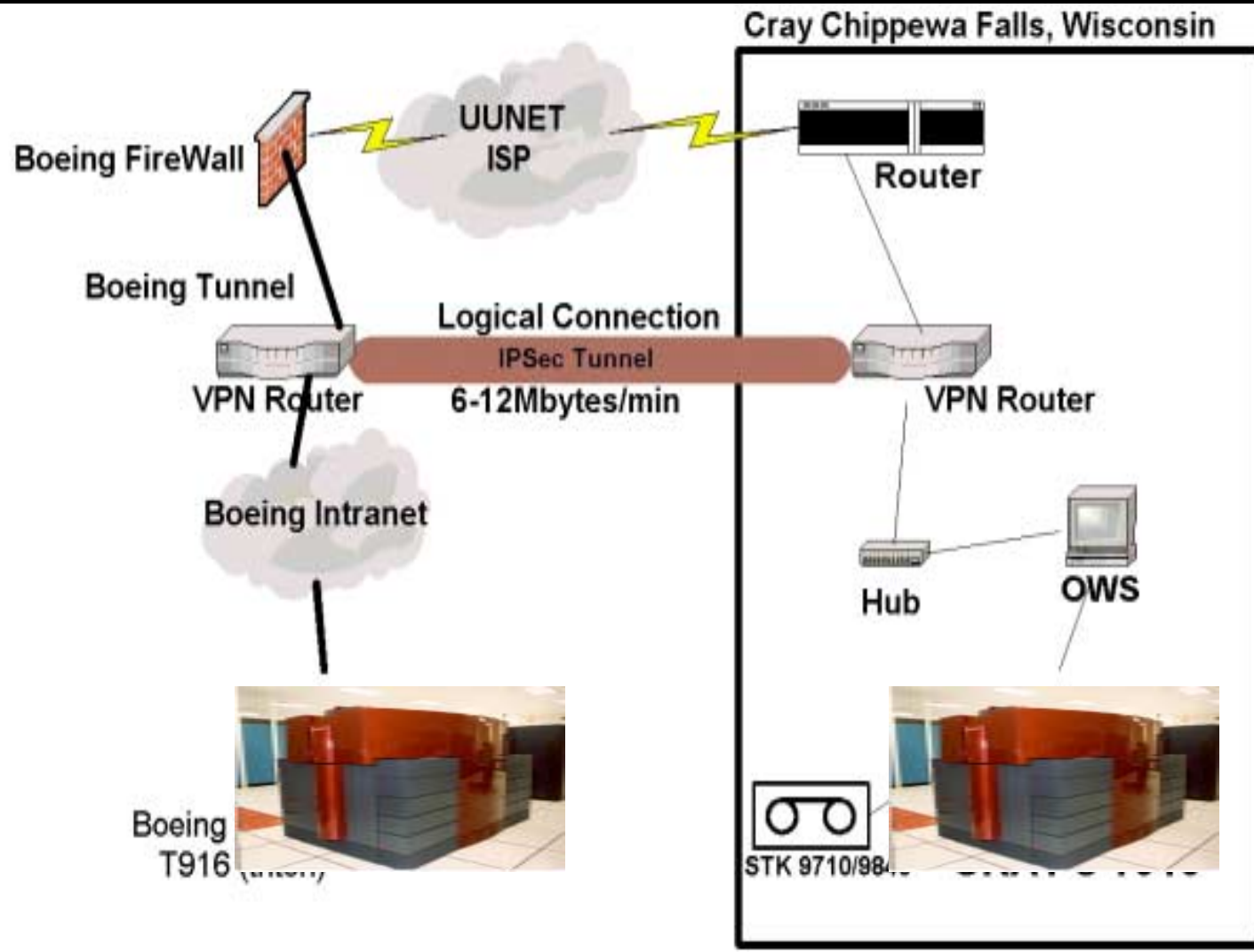



When and how did we do this ?

- **Before and during Christmas time 2001**
 - **Dec 22nd to Jan 2nd Boeing shut down for holidays**
 - **Tape media, STK Drives, STK Silo shipped wet**
 - **Remote T916 Service memo sent to Engr Depts**
 - **Negotiate final T932 and T916 rental agreements**
 - **Dec 20th to Jan 7th daily Telcons setup with C.F.**
 - **Cray makes rental T916 ready**
 - **Boeing successfully installed/QAed its UNICOS 10**
 - **Remote T916 service started Jan 7th on schedule and was accessible to engineers on the Boeing intranet**



The second T90

- Adding the T932 into the 'mix'
 - Visit C.F to overview physical security and T932
 - Cray Prof Services delivers 8Gw SSD code *early*
 - Scheduled weekly Telcons with C.F.
 - Feb 7th Cray gives Boeing access to T932 in C.F.
 - Boeing IT people install and test their OS on T932
 - T932 passes 15 days of rigorous Boeing QA
 - Minor software problem with 8Gw SSD code



How... managing two T90s remotely

- **Remote/Secure usage of Rental T916 and T932**
 - **Setup dual VPN network topology (see next slide)**
 - **Backup VPN routers introduced**
 - **If connectivity lost -- was T932 or Network down ?**
 - **CRAY agreed to monitor OWS per hour**

VPN for Two T916 and T932

CRAY Network Design

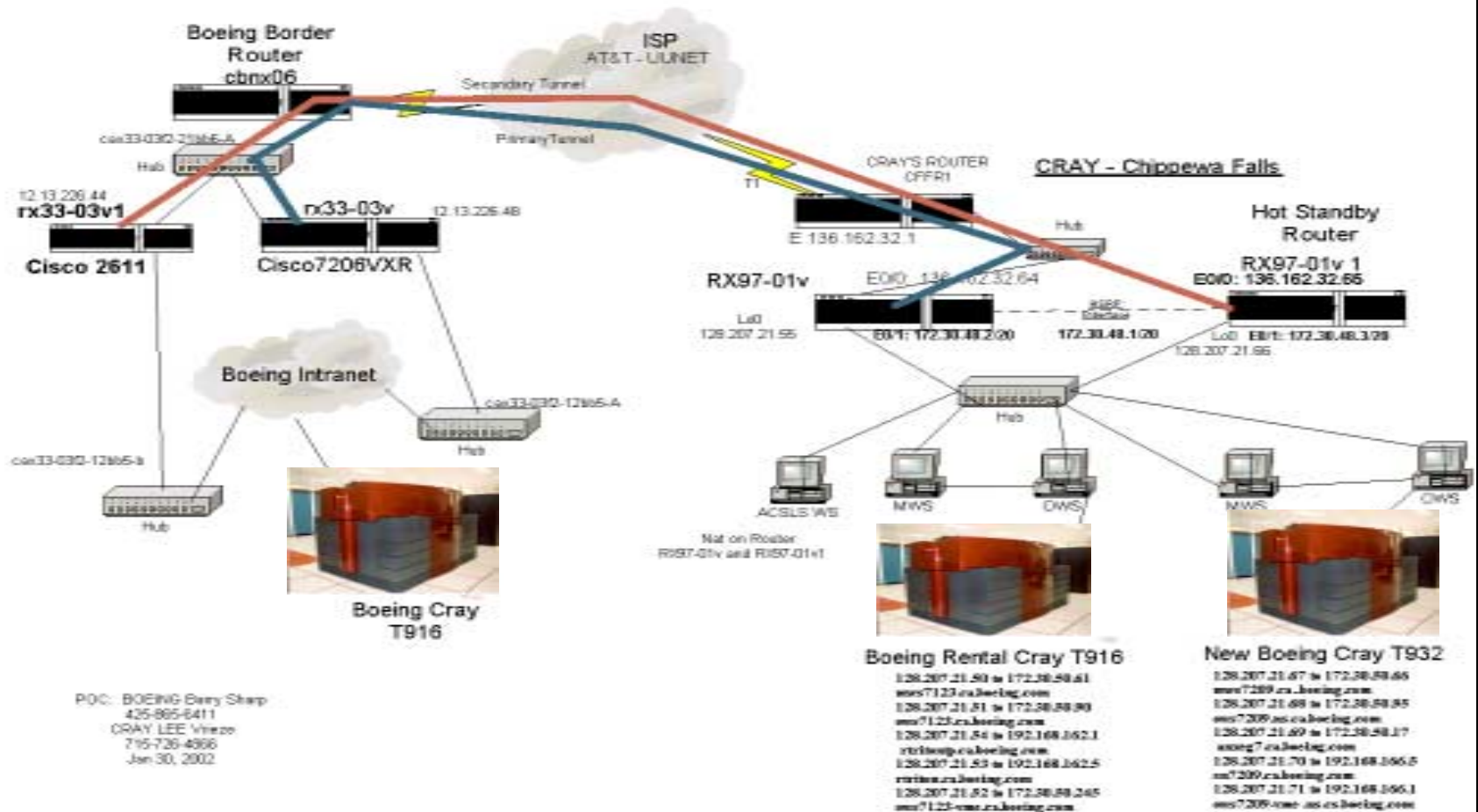



“The Final Mile”

- **February 28th T932 ships to Boeing data center**
- **March 4th the T932 arrives at data center**
- **CRAY installs the T932 in 3 days (incredible)**
- **March 6th the T932 is handed over to Boeing**
- **Boeing QA ran hw checkout for 24hrs w/o problems**
- **March 16th 30-day min 95% Effectiveness reached**
- **Boeing Accepts T932 with unique 8Gw box**
- **Rental T916 still being used remotely in C.F.**
- **March 25th T932 placed into full production**
- **Our T916 & T932 plus Remote T916 fully operational**



What Our Engineering Customer Said was...

“The total acquisition and installation of the T932 and the connection to the rental T916 has worked wonderfully. Thanks to all involved for the great work in pulling this together and executing it so well. What an incredible group of people! Thanks!!”

Boeing Director, Computer Aided Engineering

What we say...

“Thanks CRAY for a Job Well Done”



Our past and potential future

The average yearly growth in HPC at Boeing during the last 20 years on a 5-year-averaging basis is 48%

During past 4 years Boeing HPC has grown 10x

It's reasonable to assume that this past pattern can repeat over at least the next 10 years